

NFPA[®]

274

Standard Test Method to
Evaluate Fire Performance
Characteristics of Pipe Insulation

2023



NFPA[®] 274

Standard Test Method to Evaluate Fire Performance Characteristics of Pipe Insulation

2023 Edition



IMPORTANT NOTICES AND DISCLAIMERS CONCERNING NFPA® STANDARDS

NFPA® codes, standards, recommended practices, and guides (“NFPA Standards”), of which the document contained herein is one, are developed through a consensus standards development process approved by the American National Standards Institute. This process brings together volunteers representing varied viewpoints and interests to achieve consensus on fire and other safety issues. While the NFPA administers the process and establishes rules to promote fairness in the development of consensus, it does not independently test, evaluate, or verify the accuracy of any information or the soundness of any judgments contained in NFPA Standards.

The NFPA disclaims liability for any personal injury, property, or other damages of any nature whatsoever, whether special, indirect, consequential or compensatory, directly or indirectly resulting from the publication, use of, or reliance on NFPA Standards. The NFPA also makes no guaranty or warranty as to the accuracy or completeness of any information published herein.

In issuing and making NFPA Standards available, the NFPA is not undertaking to render professional or other services for or on behalf of any person or entity. Nor is the NFPA undertaking to perform any duty owed by any person or entity to someone else. Anyone using this document should rely on his or her own independent judgment or, as appropriate, seek the advice of a competent professional in determining the exercise of reasonable care in any given circumstances.

The NFPA has no power, nor does it undertake, to police or enforce compliance with the contents of NFPA Standards. Nor does the NFPA list, certify, test, or inspect products, designs, or installations for compliance with this document. Any certification or other statement of compliance with the requirements of this document shall not be attributable to the NFPA and is solely the responsibility of the certifier or maker of the statement.

REVISION SYMBOLS IDENTIFYING CHANGES FROM THE PREVIOUS EDITION

Text revisions are shaded. A **Δ** before a section number indicates that words within that section were deleted and a **Δ** to the left of a table or figure number indicates a revision to an existing table or figure. When a chapter was heavily revised, the entire chapter is marked throughout with the **Δ** symbol. Where one or more sections were deleted, a **•** is placed between the remaining sections. Chapters, annexes, sections, figures, and tables that are new are indicated with an **N**.

Note that these indicators are a guide. Rearrangement of sections may not be captured in the markup, but users can view complete revision details in the First and Second Draft Reports located in the archived revision information section of each code at www.nfpa.org/docinfo. Any subsequent changes from the NFPA Technical Meeting, Tentative Interim Amendments, and Errata are also located there.

REMINDER: UPDATING OF NFPA STANDARDS

Users of NFPA codes, standards, recommended practices, and guides (“NFPA Standards”) should be aware that these documents may be superseded at any time by the issuance of a new edition, may be amended with the issuance of Tentative Interim Amendments (TIAs), or be corrected by Errata. It is intended that through regular revisions and amendments, participants in the NFPA standards development process consider the then-current and available information on incidents, materials, technologies, innovations, and methods as these develop over time and that NFPA Standards reflect this consideration. Therefore, any previous edition of this document no longer represents the current NFPA Standard on the subject matter addressed. NFPA encourages the use of the most current edition of any NFPA Standard [as it may be amended by TIA(s) or Errata] to take advantage of current experience and understanding. An official NFPA Standard at any point in time consists of the current edition of the document, including any issued TIAs and Errata then in effect.

To determine whether an NFPA Standard has been amended through the issuance of TIAs or corrected by Errata, visit the “Codes & Standards” section at www.nfpa.org.

ADDITIONAL IMPORTANT NOTICES AND DISCLAIMERS CONCERNING NFPA® STANDARDS

Updating of NFPA Standards

Users of NFPA codes, standards, recommended practices, and guides (“NFPA Standards”) should be aware that these documents may be superseded at any time by the issuance of a new edition, may be amended with the issuance of Tentative Interim Amendments (TIAs), or be corrected by Errata. It is intended that through regular revisions and amendments, participants in the NFPA standards development process consider the then-current and available information on incidents, materials, technologies, innovations, and methods as these develop over time and that NFPA Standards reflect this consideration. Therefore, any previous edition of this document no longer represents the current NFPA Standard on the subject matter addressed. NFPA encourages the use of the most current edition of any NFPA Standard [as it may be amended by TIA(s) or Errata] to take advantage of current experience and understanding. An official NFPA Standard at any point in time consists of the current edition of the document, including any issued TIAs and Errata then in effect.

To determine whether an NFPA Standard has been amended through the issuance of TIAs or corrected by Errata, visit the “Codes & Standards” section at www.nfpa.org.

Interpretations of NFPA Standards

A statement, written or oral, that is not processed in accordance with Section 6 of the Regulations Governing the Development of NFPA Standards shall not be considered the official position of NFPA or any of its Committees and shall not be considered to be, nor be relied upon as, a Formal Interpretation.

Patents

The NFPA does not take any position with respect to the validity of any patent rights referenced in, related to, or asserted in connection with an NFPA Standard. The users of NFPA Standards bear the sole responsibility for determining the validity of any such patent rights, as well as the risk of infringement of such rights, and the NFPA disclaims liability for the infringement of any patent resulting from the use of or reliance on NFPA Standards.

NFPA adheres to the policy of the American National Standards Institute (ANSI) regarding the inclusion of patents in American National Standards (“the ANSI Patent Policy”), and hereby gives the following notice pursuant to that policy:

NOTICE: The user’s attention is called to the possibility that compliance with an NFPA Standard may require use of an invention covered by patent rights. NFPA takes no position as to the validity of any such patent rights or as to whether such patent rights constitute or include essential patent claims under the ANSI Patent Policy. If, in connection with the ANSI Patent Policy, a patent holder has filed a statement of willingness to grant licenses under these rights on reasonable and nondiscriminatory terms and conditions to applicants desiring to obtain such a license, copies of such filed statements can be obtained, on request, from NFPA. For further information, contact the NFPA at the address listed below.

Law and Regulations

Users of NFPA Standards should consult applicable federal, state, and local laws and regulations. NFPA does not, by the publication of its codes, standards, recommended practices, and guides, intend to urge action that is not in compliance with applicable laws, and these documents may not be construed as doing so.

Copyrights

NFPA Standards are copyrighted. They are made available for a wide variety of both public and private uses. These include both use, by reference, in laws and regulations, and use in private self-regulation, standardization, and the promotion of safe practices and methods. By making these documents available for use and adoption by public authorities and private users, the NFPA does not waive any rights in copyright to these documents.

Use of NFPA Standards for regulatory purposes should be accomplished through adoption by reference. The term “adoption by reference” means the citing of title, edition, and publishing information only. Any deletions, additions, and changes desired by the adopting authority should be noted separately in the adopting instrument. In order to assist NFPA in following the uses made of its documents, adopting authorities are requested to notify the NFPA (Attention: Secretary, Standards Council) in writing of such use. For technical assistance and questions concerning adoption of NFPA Standards, contact NFPA at the address below.

For Further Information

All questions or other communications relating to NFPA Standards and all requests for information on NFPA procedures governing its codes and standards development process, including information on the procedures for requesting Formal Interpretations, for proposing Tentative Interim Amendments, and for proposing revisions to NFPA standards during regular revision cycles, should be sent to NFPA headquarters, addressed to the attention of the Secretary, Standards Council, NFPA, 1 Batterymarch Park, P.O. Box 9101, Quincy, MA 02269-9101; email: stds_admin@nfpa.org.

For more information about NFPA, visit the NFPA website at www.nfpa.org. All NFPA codes and standards can be viewed at no cost at www.nfpa.org/docinfo.

Copyright © 2022 National Fire Protection Association®. All Rights Reserved.

NFPA® 274

Standard

Test Method to Evaluate Fire Performance Characteristics of Pipe Insulation

2023 Edition

This edition of NFPA 274, *Standard Test Method to Evaluate Fire Performance Characteristics of Pipe Insulation*, was prepared by the Technical Committee on Fire Tests. It was issued by the Standards Council on November 29, 2022, with an effective date of December 19, 2022, and supersedes all previous editions.

This edition of NFPA 274 was approved as an American National Standard on December 19, 2022.

Origin and Development of NFPA 274

NFPA 274, *Test Method to Evaluate Fire Performance Characteristics of Pipe Insulation*, was developed by the Technical Committee on Fire Tests to fill the need for a standard method of determining the fire performance of pipe insulation materials. Other codes and standards have identified the issue of the installation of such materials in air-handling plenums. Although NFPA 274 does not prescribe pass/fail criteria, suggested acceptance criteria are provided in Annex B for consideration by the other referencing codes and standards.

The 2009 edition of NFPA 274 included a new requirement for a quantifiable determination of the presence of flames at the top of the exhaust chase using thermocouples.

The 2013 edition was a reconfirmation of the previous edition.

The 2018 and 2023 editions include updates to the latest referenced codes and standards and revisions to the annex.

Technical Committee on Fire Tests

Barry L. Badders, Jr., *Chair*
Intertek Testing Services, TX [RT]

Hubert Biteau, S-E-A, Ltd., CO [SE]
Benjamin H. Caldwell, Skidmore, Owings & Merrill LLP (SOM), NY [SE]
Karen C. Carpenter, Southwest Research Institute, TX [RT]
Rick D. Davis, National Institute of Standards & Technology (NIST), MD [RT]
Scott E. Dillon, Crane Engineering, MN [SE]
William E. Fitch, Phyrefish.com, FL [SE]
Richard G. Gann, Gaithersburg, MD [SE]
Marcelo M. Hirschler, GBH International, CA [SE]
Paul A. Hough, Armstrong World Industries, Inc., PA [M]
William E. Koffel, Koffel Associates, Inc., MD [SE]
Sergei V. Levchik, Israel Chemicals Ltd. (ICL-IP), NY [M]
 Rep. ACC-North American Flame Retardant Alliance
Michael E. Luna, ICC NTA, LLC., TX [RT]
James Andrew Lynch, The Fire Solutions Group, PA [SE]
John Martell, Professional Fire Fighters of Maine/IAFF, ME [L]
 Rep. International Association of Fire Fighters

Rodney A. McPhee, Canadian Wood Council, Canada [M]
Kathleen A. Newman, Firetect, CA [M]
Nicholas Ozog, Wiss, Janney, Elstner Associates, Inc., IL [SE]
Arthur J. Parker, JENSEN HUGHES, MD [SE]
Bill Perdue, American Home Furnishings Alliance (AHFA), NC [U]
Shamim Rashid-Sumar, National Ready Mixed Concrete Assn., NY [M]
Michael L. Savage, Sr., Marion County Building Safety, FL [E]
Michael Schmeida, Gypsum Association, OH [M]
David T. Sheppard, US Bureau of Alcohol, Tobacco, Firearms & Explosives, MD [RT]
Dwayne Sloan, UL LLC, NC [RT]
Kuma Sumathipala, American Wood Council, VA [M]
Robert J. Wills, American Iron and Steel Institute, AL [M]
Dong Zeng, FM Global, MA [I]
 Rep. FM Global

Alternates

Marc Alam, Canadian Wood Council, Canada [M]
 (Alt. to Rodney A. McPhee)
Richard J. Davis, FM Global, MA [I]
 (Alt. to Dong Zeng)
Timothy Earl, GBH International, MI [SE]
 (Alt. to Marcelo M. Hirschler)
Stephen Paul Fuss, US Bureau of Alcohol, Tobacco, Firearms & Explosives, MD [RT]
 (Alt. to David T. Sheppard)
Justin A. Geiman, Fire and Risk Alliance LLC, MD [SE]
 (Alt. to James Andrew Lynch)
Karl Dana Houser, Intertek, PA [RT]
 (Alt. to Barry L. Badders, Jr.)
Jonathan Humble, American Iron and Steel Institute, CT [M]
 (Alt. to Robert J. Wills)

Marc L. Janssens, Southwest Research Institute, TX [RT]
 (Alt. to Karen C. Carpenter)
Elizabeth C. Keller, Engineering Systems, Inc., NC [SE]
 (Alt. to Scott E. Dillon)
Cori Leffler, Firetect, CA [M]
 (Alt. to Kathleen A. Newman)
Daniel A. Martin, JENSEN HUGHES, MD [SE]
 (Alt. to Arthur J. Parker)
Jason V. Smart, American Wood Council (AWC), VA [M]
 (Alt. to Kuma Sumathipala)
Matthew T. Vinci, International Association of Fire Fighters, DC [L]
 (Alt. to John Martell)
Luke C. Woods, UL LLC, MA [RT]
 (Alt. to Dwayne Sloan)

Nonvoting

Rohit “Rik” Khanna, US Consumer Product Safety Commission (CPSC), MD [C]
 Rep. US Consumer Product Safety Commission

Andrew Lock, US Consumer Product Safety Commission, MD [C]
 Rep. US Consumer Product Safety Commission

Tracy L. Vecchiarelli, NFPA Staff Liaison

This list represents the membership at the time the Committee was balloted on the final text of this edition. Since that time, changes in the membership may have occurred. A key to classifications is found at the back of the document.

NOTE: Membership on a committee shall not in and of itself constitute an endorsement of the Association or any document developed by the committee on which the member serves.

Committee Scope: This Committee shall have primary responsibility for documents on fire testing procedures, for reviewing existing fire test standards and recommending appropriate action to NFPA, for recommending the application of and advising on the interpretation of acceptable test standards for fire problems of concern to NFPA technical committees and members, and for acting in a liaison capacity between NFPA and the committees of other organizations writing fire test standards. This Committee does not cover fire tests that are used to evaluate extinguishing agents, devices, or systems.

Contents

Chapter 1 Administration	274- 4		
1.1 Scope.	274- 4	5.8 Data Acquisition.	274- 8
1.2 Purpose.	274- 4	5.9 Photographic Equipment.	274- 9
1.3 Application.	274- 4	Chapter 6 Calibration	274- 9
1.4 Units and Formulas.	274- 4	6.1 Calibration of Equipment.	274- 9
Chapter 2 Referenced Publications	274- 4	6.2 Daily Calibration.	274- 9
2.1 General.	274- 4	Chapter 7 Test Procedure	274- 9
2.2 NFPA Publications. (Reserved)	274- 4	7.1 Testing Procedure.	274- 9
2.3 Other Publications.	274- 4	Chapter 8 Calculations	274- 10
2.4 References for Extracts in Mandatory Sections. (Reserved)	274- 4	8.1 Method of Calculation.	274- 10
Chapter 3 Definitions	274- 4	8.2 Symbols.	274- 10
3.1 General.	274- 4	8.3 Calibration Constant Using Propane.	274- 10
3.2 NFPA Official Definitions.	274- 5	8.4 Heat Release for Test Specimens.	274- 10
3.3 General Definitions. (Reserved)	274- 5	8.5 Smoke Obscuration.	274- 10
Chapter 4 Test Specimens	274- 5	Chapter 9 Report of Results	274- 11
4.1 Size and Preparation.	274- 5	9.1 Documentation.	274- 11
4.2 Conditioning.	274- 5	Annex A Explanatory Material	274- 11
Chapter 5 Test Equipment and Instrumentation	274- 5	Annex B Commentary	274- 11
5.1 Pipe Chase.	274- 5	Annex C Heat Release Calculations Using Additional Gas Analysis	274- 12
5.2 Ignition Source.	274- 6	Annex D Informational References	274- 13
5.3 Canopy Hood and Exhaust Duct.	274- 7	Index	274- 14
5.4 Instrumentation in Exhaust Duct.	274- 7		
5.5 Sampling Line.	274- 8		
5.6 Gas Sampling and Analysis Equipment.	274- 8		
5.7 Smoke Density Measuring Instruments.	274- 8		

NFPA 274

Standard

Test Method to Evaluate Fire Performance Characteristics of Pipe Insulation

2023 Edition

IMPORTANT NOTE: This NFPA document is made available for use subject to important notices and legal disclaimers. These notices and disclaimers appear in all publications containing this document and may be found under the heading “Important Notices and Disclaimers Concerning NFPA Standards.” They can also be viewed at www.nfpa.org/disclaimers or obtained on request from NFPA.

UPDATES, ALERTS, AND FUTURE EDITIONS: New editions of NFPA codes, standards, recommended practices, and guides (i.e., NFPA Standards) are released on scheduled revision cycles. This edition may be superseded by a later one, or it may be amended outside of its scheduled revision cycle through the issuance of Tentative Interim Amendments (TIAs). An official NFPA Standard at any point in time consists of the current edition of the document, together with all TIAs and Errata in effect. To verify that this document is the current edition or to determine if it has been amended by TIAs or Errata, please consult the National Fire Codes® Subscription Service or the “List of NFPA Codes & Standards” at www.nfpa.org/docinfo. In addition to TIAs and Errata, the document information pages also include the option to sign up for alerts for individual documents and to be involved in the development of the next edition.

NOTICE: An asterisk (*) following the number or letter designating a paragraph indicates that explanatory material on the paragraph can be found in Annex A.

A reference in brackets [] following a section or paragraph indicates material that has been extracted from another NFPA document. Extracted text may be edited for consistency and style and may include the revision of internal paragraph references and other references as appropriate. Requests for interpretations or revisions of extracted text shall be sent to the technical committee responsible for the source document.

Information on referenced and extracted publications can be found in Chapter 2 and Annex D.

Chapter 1 Administration

1.1* Scope. This standard describes a test method for determining the heat release and the smoke generation of pipe insulation assemblies mounted on steel pipes in a full-scale pipe chase.

1.2 Purpose.

1.2.1 This is a test method for an examination of the complete insulation assembly, including elbows, in an actual configuration that is found in the end use application. This test method shall be used to ascertain the resulting fire performance characteristics of the insulation assembly when exposed to a standard flaming ignition source in a standard pipe chase.

1.2.2* The results from this procedure provide information that shall be permitted to be used as an aid in the selection of pipe insulation assemblies that provide less contribution of heat, flame, and smoke to fire scenarios. The configuration and flame exposure that the specimens incur during the test produce results that clearly differentiate between products.

1.3 Application.

1.3.1* This test procedure shall be used to determine performance of pipe insulation assemblies exposed to a flaming ignition source.

1.3.2 The specimens shall include any jackets, elbows, tapes, sealants, coatings, adhesives, or other accessories used with the insulation in practice.

1.3.3* The test shall determine the potential extent to which the pipe insulation assemblies contribute to fire growth and the potential for fire spread under the particular conditions simulated.

1.3.4 Full-size specimens of pipe insulation assemblies shall be enclosed in a pipe chase and exposed to a gas burner ignition source.

1.3.5 During the test, the gas burner shall be set at an output level of 20 kW for the first 3 minutes and subsequently 70 kW for an additional 7 minutes.

1.3.6* Measurements shall be made of heat release and smoke density.

1.3.7 The total heat released, the peak rate of heat release, and the total smoke released shall be determined from the heat release and smoke density measurements, respectively.

1.3.8 Observations shall be taken during the test of flame spread out the top of the chase and other visual events.

1.3.9 Post-test observations of the condition of the specimens shall be recorded.

1.4 Units and Formulas.

1.4.1 SI Units. Metric units of measurement in this standard are in accordance with the modernized metric system known as the International System of Units (SI).

1.4.2 Primary Values. The SI value for a measurement and the equivalent inch-pound value given in parentheses shall each be acceptable for use as primary units for satisfying the requirements of this standard.

Chapter 2 Referenced Publications

2.1 General. The documents or portions thereof listed in this chapter are referenced within this standard and shall be considered part of the requirements of this document.

2.2 NFPA Publications. (Reserved)

2.3 Other Publications.

Merriam-Webster's Collegiate Dictionary, 11th edition, Merriam-Webster, Inc., Springfield, MA, 2003.

2.4 References for Extracts in Mandatory Sections. (Reserved)

Chapter 3 Definitions

3.1 General. The definitions contained in this chapter shall apply to the terms used in this standard. Where terms are not defined in this chapter or within another chapter, they shall be defined using their ordinarily accepted meanings within the context in which they are used. *Merriam-Webster's Collegiate*

Dictionary, 11th edition, shall be the source for the ordinarily accepted meaning.

3.2 NFPA Official Definitions.

3.2.1 Shall. Indicates a mandatory requirement.

3.2.2 Should. Indicates a recommendation or that which is advised but not required.

3.2.3 Standard. An NFPA standard, the main text of which contains only mandatory provisions using the word “shall” to indicate requirements and that is in a form generally suitable for mandatory reference by another standard or code or for adoption into law. Nonmandatory provisions are not to be considered a part of the requirements of a standard and shall be located in an appendix, annex, footnote, informational note, or other means as permitted in the NFPA manuals of style. When used in a generic sense, such as in the phrases “standards development process” or “standards development activities,” the term “standards” includes all NFPA standards, including codes, standards, recommended practices, and guides.

3.3 General Definitions. (Reserved)

Chapter 4 Test Specimens

4.1 Size and Preparation.

4.1.1 The test specimen shall consist of the actual pipe insulation assemblies, including elbows, jackets, lagging, tapes, sealants, coatings, and adhesives, mounted on three DN 60 metric size or 2 in. nominal pipe size steel pipes.

4.1.2 The three steel pipes shall be L shaped, each with a vertical and horizontal section joined (by welding) with a short radius welded elbow of the same diameter.

4.1.2.1 The horizontal section of the welded pipe, including the elbow, shall be 1120 mm \pm 13 mm (44 in. \pm 1/2 in.) long, and the vertical section, including the elbow, shall be 1650 mm \pm 13 mm (65 in. \pm 1/2 in.).

4.1.2.2 Each pipe shall have a cap screwed to the end of the vertical run, the cap having a hole through which a threaded eyebolt has been fastened. The ends of the horizontal run of pipes shall not be capped.

4.1.2.3 The eyebolt shall be opened to form a hook so that the pipe can be hung on the rod across the top of the chase.

4.1.3 The L-shaped steel pipes shall be covered with insulation assemblies.

4.1.3.1 The vertical section of the insulation assembly shall be a minimum of 1520 mm (60 in.) from its top to the top of the horizontal section of the assembly.

4.1.3.2 The horizontal section shall be a minimum of 760 mm (30 in.) from the front of the chase to the vertical section.

4.1.3.3 As an alternative to 4.1.3.1 and 4.1.3.2, the vertical section of the insulation assembly shall be a minimum of 1525 mm (60 in.), and the horizontal section shall be a minimum of 760 mm (30 in.) in addition to the elbow or miter at the elbow.

4.1.4 The pipes shall be positioned in the chase with the middle pipe centered in the width of the chase and the three

pipes 165 mm \pm 3 mm (6 1/2 in. \pm 1/8 in.) apart, measured centerline to centerline.

4.1.4.1 The pipes shall be centered front to back in the vertical portion of the chase and their horizontal centerline 150 mm \pm 13 mm (6 in. \pm 1/2 in.) below the top of the horizontal portion of the interior of the chase.

4.2 Conditioning.

4.2.1 The test specimen shall be conditioned for at least 48 hours prior to testing at 23°C \pm 3°C (73°F \pm 5°F) and at relative humidity of 50 percent \pm 5 percent.

4.2.2 Test specimens shall be tested within 20 minutes of removal from such conditions if the test conditions differ from those specified in this section.

Chapter 5 Test Equipment and Instrumentation

5.1 Pipe Chase.

5.1.1 The chase shall be made of 1.37 mm [0.054 in. (16 gauge)] steel lined with nominal 13 mm (0.5 in.) thick calcium silicate board and stiffened with angle or bar stock.

5.1.2 The overall height inside the chase shall be 2030 mm \pm 13 mm (80 in. \pm 1/2 in.), and the width shall be 610 mm \pm 13 mm (24 in. \pm 1/2 in.), as shown in Figure 5.1.2.

5.1.3 The vertical section shall be 460 mm \pm 13 mm (18 in. \pm 1/2 in.) deep, while the horizontal section shall be 460 mm \pm 13 mm (18 in. \pm 1/2 in.) high and 1220 mm \pm 13 mm (48 in. \pm 1/2 in.) deep, as shown in Figure 5.1.2.

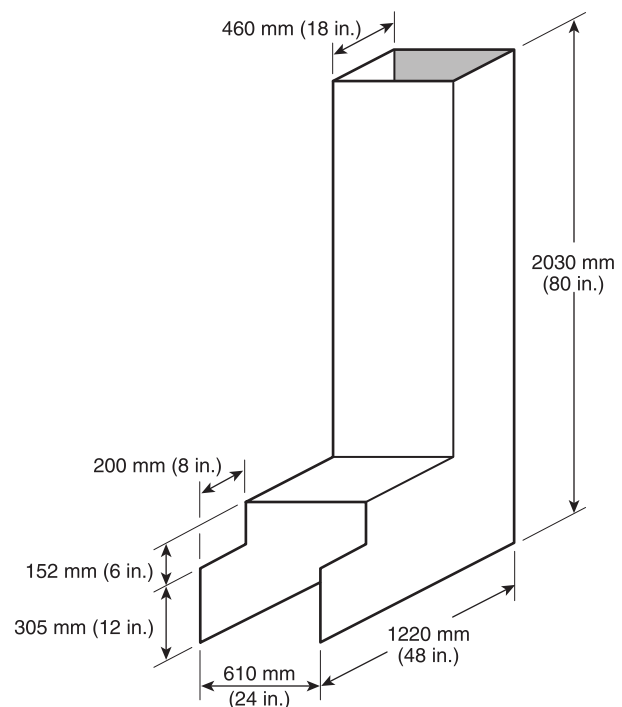

FIGURE 5.1.2 Pipe Chase Interior Dimensions.

5.1.4 Specimens mounted on steel pipes shall be hung from a 27 mm (1 1/16 in.) diameter steel rod centered across the top of the vertical chase.

5.1.5 A pan to capture any dripping and falling materials shall be made to fit in the bottom of the chase.

5.1.6 The pan shall be made of tinned steel flashing material 710 mm (28 in.) wide and 1220 mm (48 in.) long.

5.1.7 Approximately 51 mm (2 in.) of either side of the 1220 mm (48 in.) length and one end shall be bent 90 degrees to form the sides of the pan that will fit into the bottom of the chase.

5.1.8 The open side of the pan shall face outward.

5.1.9 Heavy metal tape shall be used to cover any gaps between the pan and the walls of the chase.

5.1.10 The pan shall be replaced following any test after which material adheres to the pan.

5.1.11 Three Type K 1 mm (1/16 in.) diameter ungrounded inconel-sheathed thermocouples shall be located 305 mm ± 6 mm (12 in. ± 1/4 in.) above the top of the chase. The thermocouples shall be 230 mm ± 6 mm (9 in. ± 1/4 in.) from the back wall of the chase and equally spaced across the interior width of the chase.

5.2 Ignition Source.

5.2.1 The ignition source for the test shall be a gas burner with nominal dimensions of 305 mm × 305 mm × 152 mm (12 in. × 12 in. × 6 in.), as shown in Figure 5.2.1.

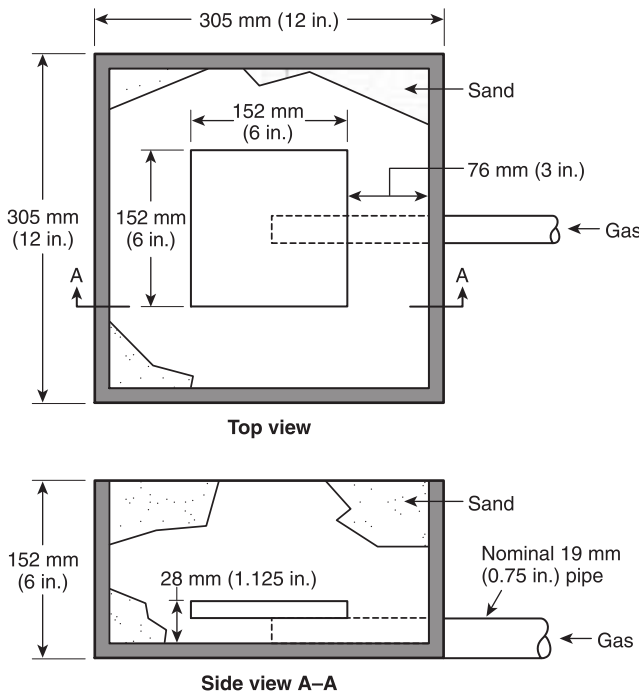

FIGURE 5.2.1 Gas Burner.

5.2.2 A minimum 102 mm (4 in.) layer of sand shall be used to provide a horizontal surface through which the gas is supplied.

5.2.3 The top surface of the burner shall be located 51 mm (2 in.) below the specimens.

5.2.4 The burner enclosure shall be located such that the edge of the diffusion surface is equidistant from both walls of the lower chase and 380 mm (15 in.) from the front of the pipe chase, as shown in Figure 5.2.4.

5.2.5 The gas supply to the burner shall be of chemically pure (C.P.) grade propane (99 percent purity or better).

5.2.6* The burner shall be capable of producing a net heat output of 20 kW ± 1 kW for 3 minutes followed by net heat output of 70 kW ± 4 kW for 7 minutes.

5.2.7 Flow rates shall be calculated using the net heat of combustion for propane of 85 MJ/m³ at standard conditions of 20°C (68°F) temperature and 100 kPa (14.70 psia) pressure.

5.2.8 The gas flow rate shall be metered throughout the test, with an accuracy within ±3 percent.

5.2.9 The heat output from the burner shall be controlled to within ±5 percent.

5.2.10 The burner design shall allow switching from 20 kW to 70 kW within 10 seconds.

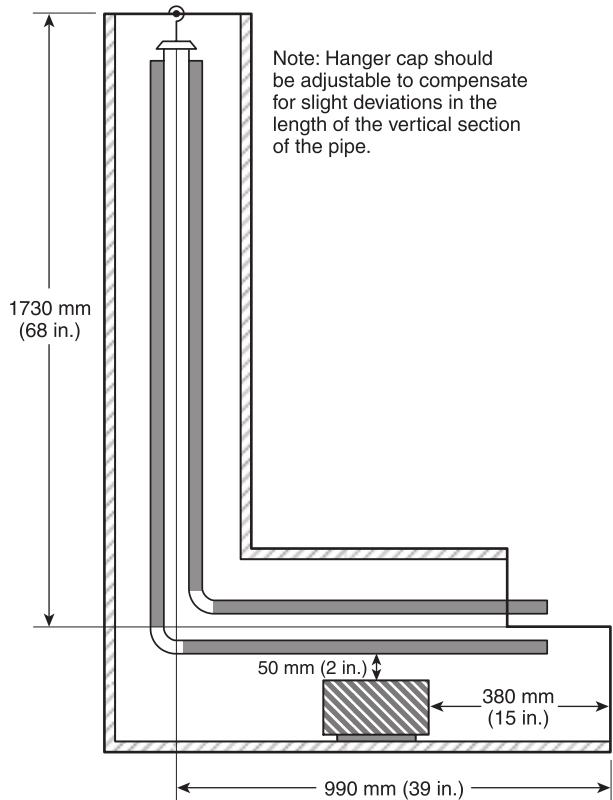

FIGURE 5.2.4 Cross Section of Chase with Pipe Insulation Assembly Installed.

5.2.11 A pilot burner or a remotely controlled spark igniter shall ignite the burner.

5.2.12 Burner controls shall be provided for automatic gas supply shutoff if flameout occurs.

5.3 Canopy Hood and Exhaust Duct.

5.3.1 A hood shall be installed above the pipe chase, as shown in Figure 5.3.1.

5.3.1.1 The face dimensions of the hood shall be at least 2.44 m × 2.44 m (8 ft × 8 ft), and the depth shall be 1.1 m (3.6 ft).

5.3.1.2 The hood shall feed into a plenum having a 0.91 m × 0.91 m (3 ft × 3 ft) cross section.

5.3.1.3 The plenum shall be a minimum height of 0.91 m (3 ft).

5.3.1.4 The height given in 5.3.1.3 shall be permitted to be increased to a maximum of 1.8 m (6 ft) to satisfy building constraints.

5.3.1.5 The exhaust duct connected to the plenum shall be as follows:

- (1) A diameter of 406 mm (16 in.)
- (2) Horizontal
- (3) Permitted to have a circular aperture of 305 mm (12 in.) at its entrance or mixing vanes in the duct

5.3.2 The hood shall have sufficient draft to collect all of the combustion products leaving the chase.

5.3.3 During the test, this draft shall be capable of moving up to 3.4 m³/sec (7200 ft³/min), equivalent to 7.6 m³/sec (16,100 ft³/min) at 399°C (750°F).

5.3.4 Provision shall be made so that the draft can operate at 0.47 m³/sec to 3.4 m³/sec (1000 ft³/min to 7200 ft³/min).

5.3.5 Mixing vanes shall be required in the duct if concentration gradients are found to exist.

5.3.6 An alternative exhaust system design shall be permitted to be used if it can be calibrated as required in Section 6.1 and Section 6.2 and it meets the performance requirements in 5.3.2.

5.4 Instrumentation in Exhaust Duct.

5.4.1 The exhaust collection system shall be constructed with the following components:

- (1) A blower
- (2) A steel hood
- (3) A duct
- (4) A bidirectional probe
- (5) A thermocouple(s)
- (6) An oxygen measurement system
- (7) A smoke obscuration measurement system (white light photocell lamp/detector or laser)
- (8) A combustion gas sampling and analysis system

5.4.2 A bidirectional probe or an equivalent measuring system shall be used to measure gas velocity in the duct.

5.4.3 A typical probe, shown in Figure 5.4.3, shall consist of a short, stainless-steel cylinder with length L , inside diameter D , and a solid diaphragm in the center.

5.4.4 The pressure taps on either side of the diaphragm shall support the probe.

5.4.5 The axis of the probe shall run along the centerline of the duct, 3.35 m (11 ft) downstream from the entrance.

5.4.6 The taps shall be connected to a pressure transducer that shall be able to resolve pressure differences of 0.25 Pa (0.001 in. H₂O).

5.4.7 One pair of thermocouples shall be placed 3.35 m (11 ft) downstream of the entrance to the horizontal duct.

5.4.8 The pair of thermocouples shall straddle the center of the duct.

5.4.9 The pair of thermocouples shall be separated 51 mm (2 in.) from each other.

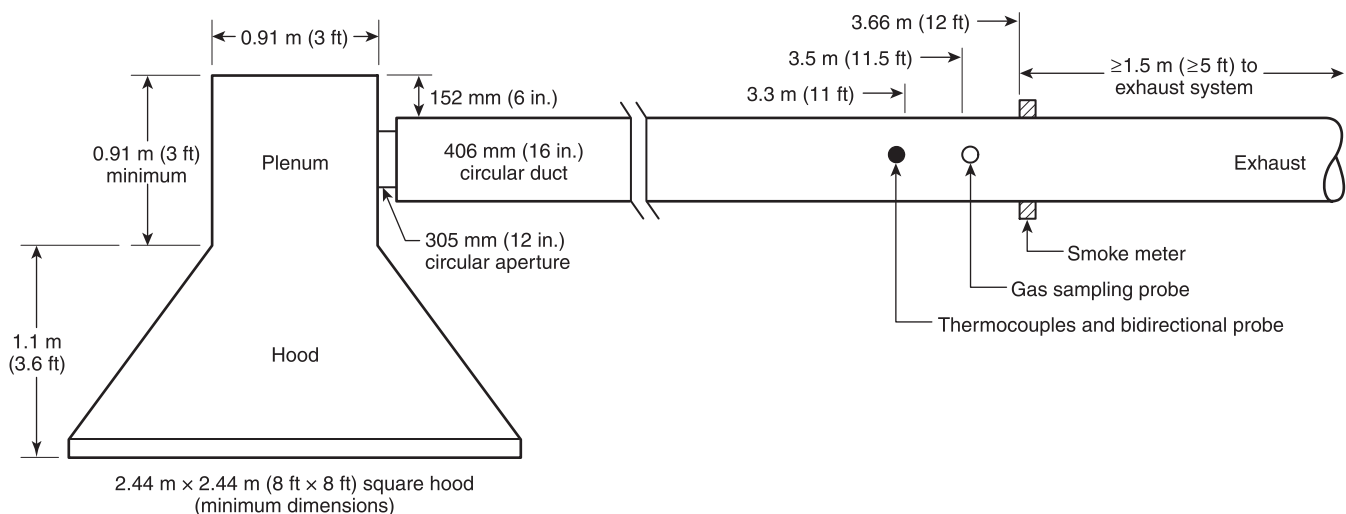
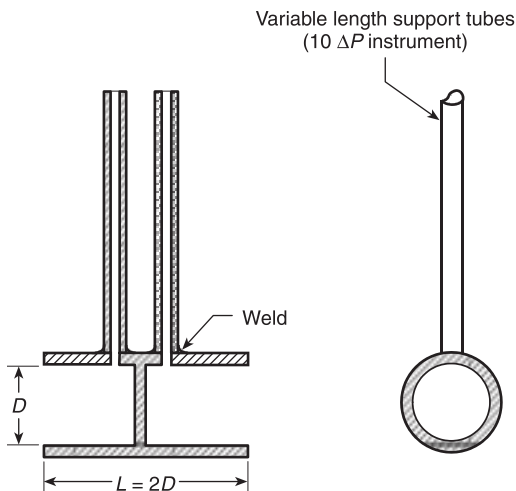

FIGURE 5.3.1 Canopy Hood and Exhaust Duct.



▲ FIGURE 5.4.3 Bidirectional Probe.

5.5 Sampling Line.

5.5.1 The gas sampling tubes shall be constructed of a material that will not affect the concentration of the combustion gas species to be analyzed.

5.5.2 The following sequence of the gas train shall be used:

- (1) Sampling probe
- (2) Soot filter
- (3) Cold trap
- (4) Gas path pump
- (5) Vent valve
- (6) Drying column
- (7) Flow controller
- (8) Oxygen analyzer

5.5.3 The gas train shall also include spanning and zeroing facilities.

5.6 Gas Sampling and Analysis Equipment.

5.6.1 A stainless steel gas sampling tube shall be located at least 10 diameters downstream from the last turn in the duct to obtain a continuously flowing sample for determining the oxygen concentration of the exhaust gas as a function of time.

5.6.2 A filter and cold trap shall be placed in line ahead of the analyzer to remove particulates and water.

5.6.3 The oxygen analyzer shall be capable of measuring the oxygen concentration in a range from 0 percent to 21 percent with an accuracy of ± 0.2 percent of full-scale setting.

5.6.3.1 The signal from the oxygen analyzer shall attain 90 percent of the calibration value within 30 seconds after introducing a step change in composition of the gas stream flowing past the inlet to the sampling tube.

5.6.4 The carbon monoxide (CO) analyzer shall have a range from 0 percent to 1.0 percent with an accuracy of ± 0.02 percent of full-scale setting.

5.6.4.1 The signal from the CO analyzer shall attain 90 percent of the calibration value within 30 seconds of a step

change in CO composition of the gas stream flowing past the inlet to the sampling tube.

5.6.5 The carbon dioxide (CO₂) analyzer shall have a range from 0 percent to 10 percent with an accuracy of ± 0.2 percent of full-scale setting.

5.6.5.1 The signal from the CO₂ analyzer shall attain 90 percent of the value within 30 seconds of a step change in CO₂ composition of the gas stream flowing past the inlet to the sampling tube.

5.7 Smoke Density Measuring Instruments.

5.7.1 The smoke density measuring system shall be a white light system or an alternative system.

5.7.2 The lamp shall be of the incandescent filament type and shall operate at a color temperature of $2900 \text{ K} \pm 100 \text{ K}$.

5.7.2.1 The lamp shall be supplied with stabilized direct current, stable within ± 0.2 percent, including temperature and short-term and long-term stability.

5.7.3 The lens system shall be selected such that the lens shall have a diameter, d , chosen with regard to the focal length, f , so that $d/f \leq 0.04$.

5.7.4 The aperture shall be placed in the focus of the lens.

5.7.5 The detector shall have a spectrally distributed response according to the CIE photopic curve.

5.7.5.1 The detector shall be linear within 5 percent over an output range of at least 3.5 decades.

5.7.5.2 The linearity of the detector shall be checked periodically with calibrated optical filters and shall cover the entire range of the instrument.

5.7.6 The system shall be mounted on the duct at a point where it will be preceded by a straight run of duct of at least 12 diameters or 5.2 m (17 ft), whichever is greater.

5.7.6.1 A photoelectric cell, whose output is directly proportional to the amount of light received, shall be mounted over the light source and connected to a recording device.

5.7.6.2 The recording device shall have an accuracy within ± 1 percent of full scale for indicating changes in the attenuation of incident light resulting from the passage of smoke, particulate, and other effluents.

5.7.6.3 The distance between the light source lens and the photocell lens shall be $914 \text{ mm} \pm 102 \text{ mm}$ ($35.6 \text{ in.} \pm 3.9 \text{ in.}$).

5.7.6.4 The cylindrical light beam shall pass through $76 \text{ mm} \pm 3 \text{ mm}$ ($2.9 \text{ in.} \pm 0.12 \text{ in.}$) diameter openings at the top and bottom of the duct, with the resultant light beam centered on the photocell.

5.7.7 An alternative smoke density measuring system shall be permitted to be used if it has been shown to produce equivalent results.

5.8 Data Acquisition.

5.8.1 A digital data acquisition system shall be used to collect and record the following:

- (1) Oxygen, carbon monoxide, and carbon dioxide analyzer measurements
- (2) Pressure gauge measurements

- (3) Temperatures
- (4) Smoke measurements

5.8.2 The speed and capacity of the data system shall be sufficient to collect the data at a minimum of every 3 seconds.

5.9 Photographic Equipment. A pretest and post-test photographic record of the test specimen shall be made.

Chapter 6 Calibration

6.1 Calibration of Equipment.

6.1.1 The equipment and instrumentation shall be calibrated.

6.1.2 The heat release instrumentation shall be calibrated by burning propane.

6.1.3 The test burner described in Section 5.2 shall be used for calibration.

6.1.4 The gas supply to the burner shall be of C.P. grade propane (99 percent purity or better.)

6.1.5 The flow rate of propane shall be metered and kept constant throughout the calibration test.

6.1.6 A heat release level of 300 kW shall be used for calibration.

6.1.7 The calibration burn shall be conducted for a period of 10 minutes.

6.1.8 A calibration constant, *C*, shall be obtained as described in Chapter 8.

6.1.8.1 A value for *C* differing more than 10 percent from the theoretical value shall not be permitted, and the equipment shall be checked.

6.1.8.2 For the exhaust duct configuration described in Section 5.3 and the velocity probe described in 5.4.2, *C* shall have a theoretical value of 2.8.

6.2 Daily Calibration.

6.2.1 Prior to the start of each day of testing, the equipment calibrations described in 6.2.2 through 6.2.7 shall be performed.

6.2.2 The oxygen analyzer shall be zeroed and spanned.

6.2.2.1 The analyzer shall be zeroed by introducing 100 percent nitrogen gas to the instrument at the same pressure and flow rate as set for the test specimen combustion gases.

6.2.2.2 The analyzer shall be spanned by introducing ambient duct air via the sample probe and adjusting the span to 20.95 percent oxygen.

6.2.2.3 The spanning and zeroing process shall continue until adjustment-free accuracy is obtained.

6.2.3 Following zeroing and spanning, linearity of the oxygen analyzer response curve shall be verified by introducing bottled gas of a known oxygen concentration to the analyzer.

6.2.3.1 The delay time of the analyzer shall be checked by introducing ambient duct air to the analyzer and noting the time at which the analyzer readings reach 90 percent of the final reading.

6.2.4 The CO analyzer and CO₂ analyzer shall be zeroed and spanned in the same manner as the oxygen analyzer.

6.2.4.1 The analyzers shall be zeroed by introducing 100 percent nitrogen gas to the instrument at the same pressure and flow rate as set for the test specimen combustion gases.

6.2.4.2 The analyzers shall be spanned by feeding each analyzer with bottled gas containing the selected concentration of span gas and adjusting for the response range of each analyzer.

6.2.5 The delay time of each analyzer shall be determined.

6.2.5.1 The delay time shall be measured by introducing either a calibration span gas (for CO and CO₂) or a zero gas (for O₂) at the sample line just outside the duct and noting the time at which the analyzer readings reach 90 percent of the final reading.

6.2.6 Linearity of the smoke density measuring system shall be verified by interrupting the light beam with multiple calibrated neutral density filters to cover the range of the recording instrument.

6.2.7 Transmittance values measured by the photometer, using neutral density filters, shall be within ± 3 percent of the calibrated value for each filter.

Chapter 7 Test Procedure

7.1 Testing Procedure.

7.1.1 Before the start of the test, the difference between the average temperature of the three thermocouples specified in 5.1.11 and the ambient room temperature shall be less than 27°C (50°F).

7.1.2 The test specimens shall be installed at equal intervals across the chase.

7.1.3 The initial exhaust hood flow rate shall be set at a rate determined to produce accurate measurements during calibration of the exhaust system and shall be adequate for the expected fire size.

7.1.4 The burner shall be positioned 380 mm \pm 5 mm (15 in. \pm 0.20 in.) from the front of the chase and centered side to side in the horizontal section of the pipe chase.

7.1.5 The data acquisition shall begin in order to record test instrumentation signals.

7.1.6 The burner shall be ignited and the flow rate shall be adjusted to provide a burner output of 20 kW \pm 1 kW.

7.1.7 The 20 kW flow shall continue for 3 minutes.

7.1.8 Within 10 seconds following the 3-minute exposure, the gas flow shall be increased to provide a 70 kW exposure for an additional 7 minutes.

7.1.9 After 10 minutes, the burner shall be turned off.

7.1.10 The post-test condition of the insulation system shall be recorded photographically and with written observations.

Chapter 8 Calculations

8.1 Method of Calculation.

8.1.1 The symbols used in this chapter shall be defined as in Section 8.2 and Annex C.

8.1.2 The equations in this chapter shall use oxygen measurement only.

8.1.3 Equations that use O₂, CO₂, CO, and water vapor shall be provided in Annex C.

8.1.4 If a CO₂ analyzer is used and CO₂ is not removed from the oxygen sampling lines, then the appropriate equations in Annex C shall be used.

8.2 Symbols. The following symbols shall be used in this chapter:

C	= calibration constant using propane (m ^{1/2} kg ^{1/2} K ^{1/2})
$\Delta H_c/r_0$	= net heat released per kg of O ₂ consumed (kJ/kg), where ΔH_c equals net heat of combustion (kJ/kg) and r_0 equals stoichiometric oxygen/fuel mass ratio
I	= light intensity
I_0	= light intensity with no smoke
k	= extinction coefficient (m ⁻¹)
l	= path length (m)
ΔP	= bidirectional probe pressure differential (Pa)
\dot{q}	= heat release rate (kW)
t	= time (sec)
t_d	= oxygen analyzer delay time (sec)
T_g	= absolute temperature of gas at the orifice meter (K)
SRR	= smoke release rate (m ² /sec)
THR	= total heat released during the test
TSR	= total smoke released (m ²)
v	= volume flow rate (m ³ /sec)
\dot{X}_{O_2}	= oxygen analyzer reading, mole fraction O ₂
$\dot{X}_{O_2}^0$	= initial value of oxygen analyzer reading
$\dot{X}_{O_2}^1$	= oxygen analyzer reading, before delay time correction

8.3 Calibration Constant Using Propane.

8.3.1 The calibration constant shall be obtained from the following equation:

[8.3.1]

$$C = \left[\frac{170}{1.10(12.77 \times 10^3)} \right] \left(\sqrt{\frac{T_g}{\Delta P}} \right) \left(\frac{1.084 - 1.4\dot{X}_{O_2}}{\dot{X}_{O_2}^0 - \dot{X}_{O_2}} \right)$$

8.3.2 In the equation given in 8.3.1, 170 shall correspond to 170 kW propane supplied, 12.77×10^3 shall equal $\Delta H_c/r_0$ for propane, and 1.10 shall be the ratio of oxygen to air molecular weight.

8.4 Heat Release for Test Specimens.

8.4.1 Prior to performing additional calculations, the oxygen analyzer time shift shall be determined by the following equation:

[8.4.1]

$$\dot{X}_{O_2}(t) = \dot{X}_{O_2}^1(t - t_d)$$

8.4.2 The heat release rate then shall be determined by the following equation:

[8.4.2]

$$\dot{q}(t) = \left(\frac{\Delta H_c}{r_0} \right) 1.10C \left(\sqrt{\frac{\Delta P}{T_g}} \right) \left(\frac{\dot{X}_{O_2}^0 - \dot{X}_{O_2}(t)}{1.084 - 1.4\dot{X}_{O_2}(t)} \right)$$

8.4.3 The value of $\Delta H_c/r_0$ for the test specimen shall be set to equal 13.1×10^3 kJ/kg unless a more accurate value is known for the test specimen.

8.4.4 The total heat released during the 10-minute (600-second) test shall be determined by the following equation:

[8.4.4]

$$\text{THR} = \sum_{t=0}^{600} \dot{q}_t(t) \Delta t$$

8.5 Smoke Obscuration.

8.5.1 The extinction coefficient (k) of smoke shall be determined by the following equation:

[8.5.1]

$$k = \frac{1}{L} \ln \left(\frac{I_0}{I} \right)$$

8.5.2 The smoke release rate (SRR) shall be calculated using the optical density per linear path length and the volumetric flow rate in the duct.

8.5.2.1 The SRR shall be determined by the following equation:

[8.5.2.1]

$$\text{SRR} = kv$$

where:

SRR = smoke release rate (m²/sec)

k = extinction coefficient

v = volumetric flow rate (m³/sec referred to 298 K)

8.5.3 Total smoke released shall be defined by the following equation:

[8.5.3]

$$\text{TSR} = \int \text{SRR} dt$$

where:

TSR = total smoke released

SRR = smoke release rate (m²/sec)

Chapter 9 Report of Results

9.1 Documentation. The following shall be reported for each test specimen:

- (1) Test specimen identification or number
- (2) Manufacturer or submitter
- (3) Date of test
- (4) Operator
- (5) Composition or generic identification of all components of the insulation assembly
- (6) Details of preparation including the location and treatment of each component in the assembly
- (7) Measured outside diameter and inside diameter of the pipe insulation
- (8) Number of replicate test specimens tested
- (9) Peak rate of heat release (kW)
- (10) Time to peak rate of heat release (seconds)
- (11) Total heat released during the 10-minute test (THR)
- (12) Plot of the heat release over time
- (13) Total smoke released during the 10-minute test (TSR)
- (14) Plot of the smoke generation over time
- (15) Pretest photographic record of test specimen
- (16) Written record of any flameout at the top of the chase
- (17) Written record of dripping or other visual observations
- (18) Post-test photographic record of test specimen

Annex A Explanatory Material

Annex A is not a part of the requirements of this NFPA document but is included for informational purposes only. This annex contains explanatory material, numbered to correspond with the applicable text paragraphs.

A.1.1 The results of the test are intended to be applicable in determining the acceptability of pipe insulation systems. Heat release rate is indicated by measurement of oxygen depletion, and smoke generation is determined by smoke density measurement.

A.1.2.2 Heat and smoke release rate measurements are sources of useful information for the regulation of materials in buildings and product development. They provide a quantitative measure of specific changes in fire performance caused by product modifications.

A.1.3.1 The purpose of this test is to examine insulation products as complete systems and to differentiate between products with a flame spread and fire scenario to which other test methods are not always sensitive. This test ignites materials that might otherwise melt away from the ignition source. In the vertical over horizontal chase configuration used by this test, ignition can occur in the horizontal section before the material in the vertical section melts from the pipes, and if there is sufficient heat from the horizontal section the vertical material will also burn.

A.1.3.3 Insulation systems producing fires of a few kilowatts to greater than 1 megawatt have been measured in this apparatus. It is believed that because the vertical section is on top of the horizontal section this apparatus is well ventilated. The buoyant

heated gases move through the vertical section more readily than a configuration with a long horizontal section on top of a shorter vertical section.

A.1.3.6 An ignition source that will ignite a variety of insulation materials and allow differentiation of the fire performance of these materials was sought for this test. Experiments utilizing equipment similar to the pipe chase in this method were performed using a 1.81 kg (4 lb) crib made of nominal 25 mm (1 in.) thick pine lumber. The 20 kW to 70 kW gas burner roughly approximates the heat release from the 1.81 kg (4 lb) wood crib. This size ignition source was large enough to ignite all the insulation materials examined without completely consuming every type of material.

A.5.2.6 Total heat output of the burner for the full 10-minute exposure is 33 MJ \pm 2 MJ.

Annex B Commentary

This annex is not a part of the requirements of this NFPA document but is included for informational purposes only.

B.1 Measurement Section Instrumentation.

Δ B.1.1 The locations for velocity, temperature, gas analysis, and smoke photometer should be chosen to ensure that the products of combustion are well mixed and not stratified at the sampling location. The general rule should be for the duct to run a sufficient length (10 diameters) downstream from the last turn in the duct prior to the location of the instrumentation to provide for a fully developed gas flow. Mixing vanes should be used in the duct if concentration gradients exist.

Δ B.1.2 A laser beam system can be used as an alternative system for measuring smoke obscuration.

B.2 Mounting.

B.2.1 Three pipes are used to provide a configuration where radiation and reradiation can occur between burning specimens, with the center specimen potentially receiving energy on two sides. The recommended spacing between the installed insulation assemblies of 50 mm \pm 13 mm (2 in. \pm ½ in.) is a distance believed to produce significant radiation between the pipes but allow enough space for easy installation.

B.2.2 Specimens of alternative size could be tested with this method on different diameter pipes if it is not possible to manufacture material in the standard size required. The spacing between the insulation assemblies should remain 50 mm \pm 13 mm (2 in. \pm ½ in.). Any deviation from the standard should be noted in the report.

Δ B.3 Insulation Materials. The *Uniform Mechanical Code (UMC)* uses this test for regulation of pipe insulation materials in plenums and contains acceptance criteria. The *International Mechanical Code (IMC)*, *NFPA 5000*, and *NFPA 90A* use ASTM E84, *Standard Test Method for Surface Burning Characteristics of Building Materials*, or UL 723, *Test for Surface Burning Characteristics of Building Materials*, for regulation of both pipe insulation and duct insulation.